

Stainless Steel Conveyor

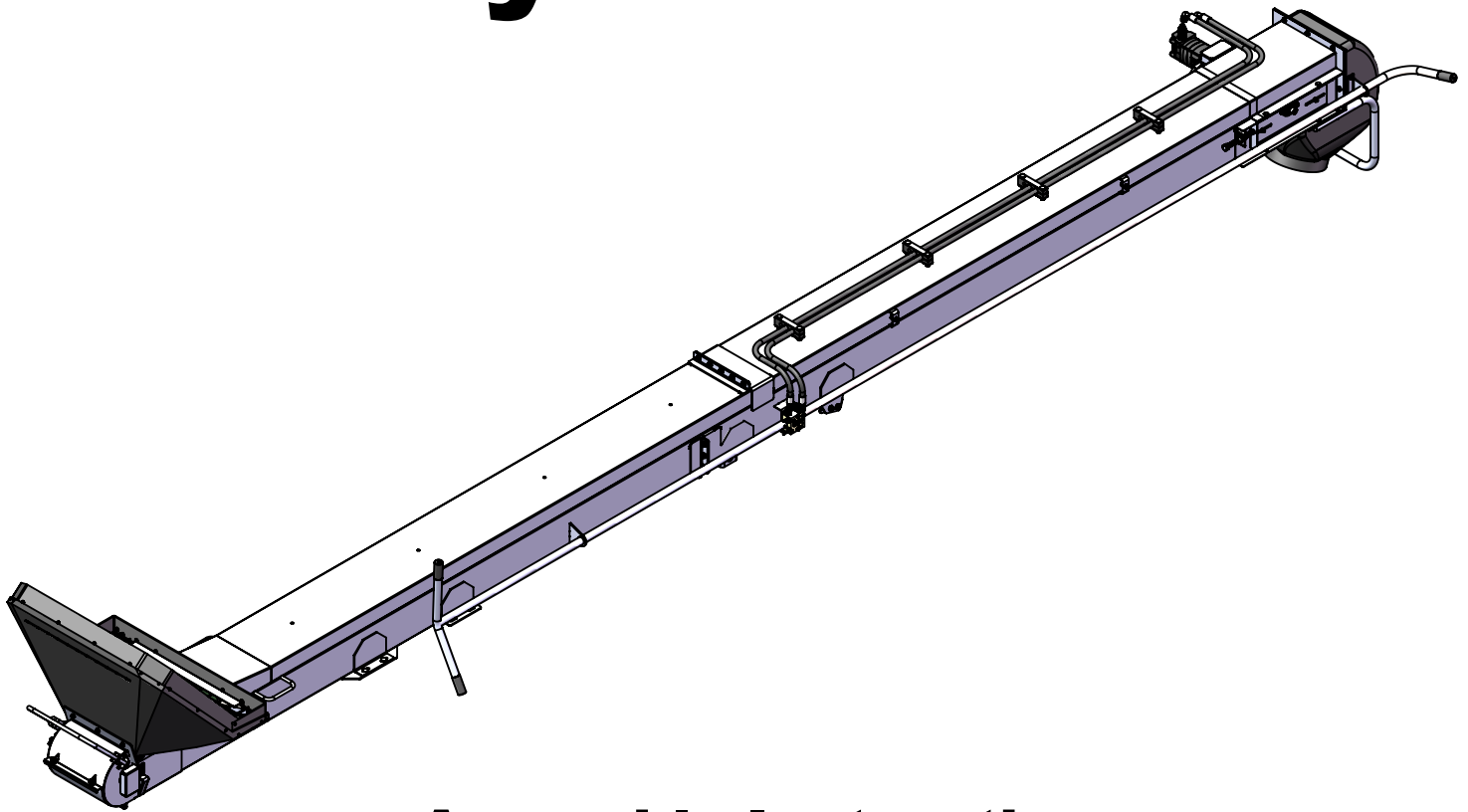

Assembly Instructions

- **JAS5000A - Long Conveyor Housing**
- **JAS5788K - Long Conveyor Parts Kit**
- **JAS5789K - Long Conveyor Hydraulic Kit**
- **JAS5100A - Short Conveyor Housing**
- **JAS5790K - Short Conveyor Parts Kit**
- **JAS5791K - Short Conveyor Hydraulic Kit**

JAS5000A - Long Conveyor Housing Parts

JAS5100A - Short Conveyor Housing Parts (see pg. 4 for part variations)

ITEM NO.	PART NUMBER	DESCRIPTION	QTY.
1	JAS5009W	Conveyor Bottom Section, Weldment	1
2	JAS5004W	Conveyor Top Section Long, Weldment	1
3	JAS5050P	Scraper Bracket	1
4	JAS5531W	Adjustable Bottom Bracket, Roller Bearing	1
5	JAS5060P	Bearing Cover (A73606)	2
6	JAS5055W	Clean-out Cover	1
7	JAS5059P	Clean-out Cover Latch	1
8	JAS5530W	Clean-out Cover Latch Handle	1
9	JAS5049P	Counterbalance Weight Plate	1
10	JAS5071P	Clamping Tab	2
11	JAS5052P	Handle, Bottom of Conveyor	1
12	JAS5013P	Hopper Mount Support R/H	1
13	JAS5014P	Hopper Mount Support L/H	1
14	JAS5030W	Tightener Bracket Weldment	1
15	JAS5034W	Tightner Bracket, Motor Side (AA59118)	1
16	JAS5037W	Cover, Top of Conveyor	1
17	JAS5039P	Plate, Motor Mount (A76121)	1
18	JAS5061P	Cover, Conveyor Drive Sprocket (A69768)	1
19	JAS5073P	Clamp Bracket, Hydraulic Hose	2
20	JAS5074P	Mount, Hydraulic Line	4
21	JAS5164P	Hose Clamp Plate (A88991)	4
22	JAS5060W	Main Latch TBH AA71555	1
23	JAS5072P	Reinforcement Plate (A74186)	1
24	SMBC-10-1.5-25-2-3	M10-1.5mm X 25mm Carriage Bolt SS	24
25	SMNF-10-1.5-3	M10-1.50mm Flange Nut SS	32
26	SMBF-08-1.25-20-2-3	M8-1.25 X 20 mm, Flange Bolt SS	24
27	SMBC-08-1.25-20-2-3	M8-1.25mm X 20mm Carriage Bolt SS	24
28	SMNF-08-1.25-3	M8-1.25mm Flange Nut SS	50
29	SMBH-08-1.25-25-2-3	M8-1.25mm X 25mm Hex Bolt SS	2
30	SMBH-08-1.25-16-2-3	M8-1.25mm X 16mm Hex Bolt SS	2
31	SMLW-010-M-3	10mm Lock Washer SS	8
32	SMBH-10-1.5-16-2-3	M10-1.5 X 16 mm Hex Bolt SS	6
33	SMNN-08-1.25-3	M8-1.25mm Nylon Lock Nut SS	11
34	SMBH-08-1.25-35-2-3	M8-1.25mm X 35mm Hex Bolt SS	1
35	SMBH-10-1.5-25-2-3	M10-1.5 X 25mm Hex Bolt SS	2
36	SMWI-16-030-M-2	M16 Flat Washer SS	4
37	SMNH-16-2.0-3	M16-2 Hex Nut SS	4
38	SMBH-16-2.0-150-2-3	M16 X 150mm Hex Bolt SS	2
39	SMWI-12-024-M-3	M12 Flat Washer SS	2
40	SMBH-12-1.75-50-2-3	M12-1.75 X 50mm Hex Bolt SS	2
41	SMNN-12-1.75-3	M12-1.75mm Nylon Lock Nut SS	2
42	SMNN-10-1.5-3	M10-1.5mm Nylon Lock Nut SS	2
43	SMBC-10-1.5-50-2-3	M10-1.5mm X 50mm Carriage Bolt SS	8
44	SMBH-08-1.25-65-2-3	M8-1.25mm X 65mm Hex Bolt SS	2
45	SISP-031-137-1	5/16" x 1-3/8" Spring Pin SS	1
46	SISP-031-300-1	5/16" x 3" Spring Pin SS	1
47	SMBH-08-1.25-50-2-3	M8-1.25mm X 50mm Hex Bolt SS	4
48	SMWI-08-018-M-2	M8 Flat Washer SS	4
80	SINN-025-1-3	1/4" Nylon Lock Nut SS	2

JAS5788K - Long Conveyor Parts Kit

JAS5790K - Short Conveyor Parts Kit (see pg. 4 for part variations)

ITEM NO.	PART NUMBER	DESCRIPTION	QTY.
30	SMBH-08-1.25-16-2-3	M8-1.25mm X 16mm Hex Bolt SS	2
49	JAS5127K	Bearing Flange Kit - SUC205	4
50	SSUC205-16	1" Stainless Steel Self-Aligning Bearing	4
51	JAS5062W	Roller, Conveyor Bottom End (AA54920)	1
52	JAS5063W	Roller, Conveyor Top Drive (AA57010)	1
53	JAS5165P	Belt Scraper, Conveyor	1
54	JAS5180P	12" Wide Cleated Conveyor Belt, Long (AA58783)	1
55	JAS5274P	Hopper, Conveyor (A74772)	1
56	JAS5157P	Seal, Conveyor Hopper (A79867)	2
57	JAS5156P	Seal, Conveyor Hopper (A90991)	2
58	JAS5158P	Seal, Conveyor Hopper L/H (A80272)	1
59	JAS5275P	Spout, Conveyor (A77122)	1
60	JAS5159P	Seal, Conveyor Hopper R/H (A79866)	1
61	JAS5155P	Seal, Top Conveyor Spout (A74543)	1
62	JAS5160P	Seal, Conveyor Spout (A80991)	2
63	JAS5162P	Hopper Extension (A74403)	1
64	JAS5161P	Hopper Extension (A74402)	1
65	JAS5527W	Coarse Screen, Conveyor (AA57626)	1
66	JAS5754K	Coupling Kit, Conveyor / Hyd. Motor	1
67	JAS5163P	Hose Clamp (A88996)	4
68	JAS5148P	Support Bracket, Hyd Valve Leaver (AA59975)	1
69	JAS5763A	Leaver, Hydraulic Valve, Upper End (A65335)	1
70	JAS5779A	Leaver, Conveyor Hydraulic Valve, Lower (AA56585)	1
71	JAS5147P	Handle, Conveyor Top (A78040)	1
72	SIR-018-050	3/16" x 1/2" Rivet	28
73	SIWI-018-056-M-3	3/16" Flat Washer SS	28
74	SMLW-008-M-3	8mm Lock Washer SS	2
80	SINN-025-1-3	1/4" Nylon Lock Nut SS	2

JAS5789K - Long Conveyor Hydraulic Kit

JAS5791K - Short Conveyor Hydraulic Kit (see pg. 4 for part variations)

ITEM NO.	PART NUMBER	DESCRIPTION	QTY.
75	T00142P	Hydraulic Motor, Conveyor (AA73606)	1
76	JAS5185P	Hydraulic Directional Valve (AA55047)	1
77	1115-10-08	#10 Male ORB to #8 Male JIC Adapter	2
78	1115-08-08	#8 Male ORB to #8 Male JIC Adapter	2
79	HYDH-001	Hydraulic line for long conveyor	2
80	SINN-025-1-3	1/4" Nylon Lock Nut SS	2

In these assembly instructions, we will reference the part numbers for the long conveyors on tow behind aircarts. If you have a short conveyor, or a tow between, reference the tables on this page for those part numbers.

Part variations

- Long and short conveyors

Part	Long Conveyor	Short Conveyor
Conveyor Top Section Weldment	JAS5004W	JAS5005W
Conveyor Belt	JAS5180P	JAS5273P
Upper Control Handle	JAS5763A	JAS5780A
Hydraulic Lines	HYDH-001	HYDH-003
Counterbalancing Weight Plate	JAS5049P	N/A

The counterbalancing weight plate (JAS5049P) comes factory installed inside the bottom conveyor housing for the long conveyors.

Part variations

- Tow behind or tow between

Part	Tow Behind	Tow Between
Main Latch	JAS5060W	JAS5512W

IMPORTANT: APPLY ANTISIEZE TO ALL THREADED STAINLESS STEEL SURFACES TO PREVENT COLD WELD!

Check out our website for a helpful assembly video
www.romafa.com/support/how-to-videos

IMPORTANT: APPLY ANTISEIZE TO ALL THREADED SURFACES!

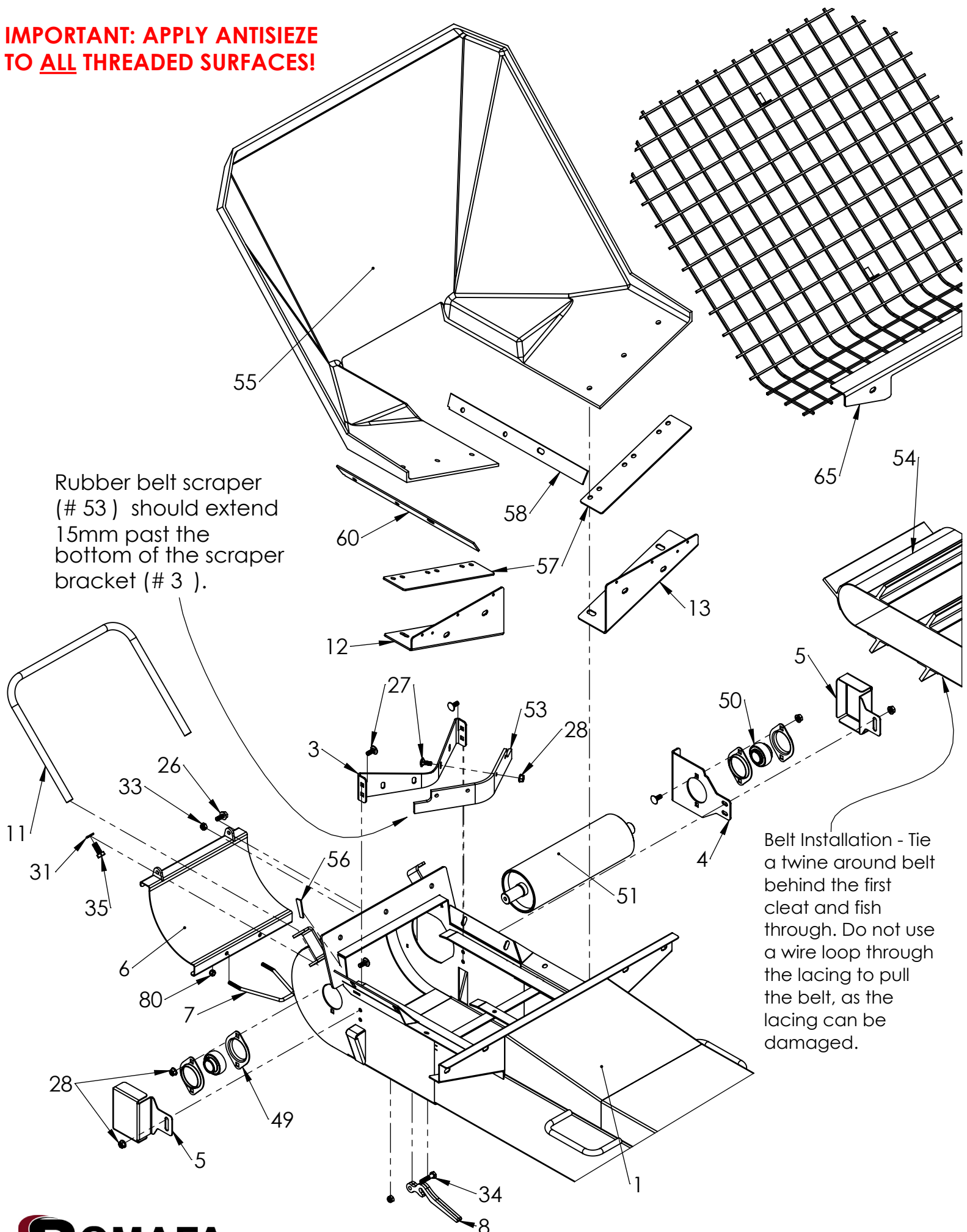

Rubber belt scraper (# 53) should extend 15mm past the bottom of the scraper bracket (# 3).

Belt Installation - Tie a twine around belt behind the first cleat and fish through. Do not use a wire loop through the lacing to pull the belt, as the lacing can be damaged.

Installing hopper

Bottom two bolts on each side, use carriage bolts (27). Install them as far up from belt as possible so they do not make contact with belt. Use flange bolts (26) for the rest of the hopper.

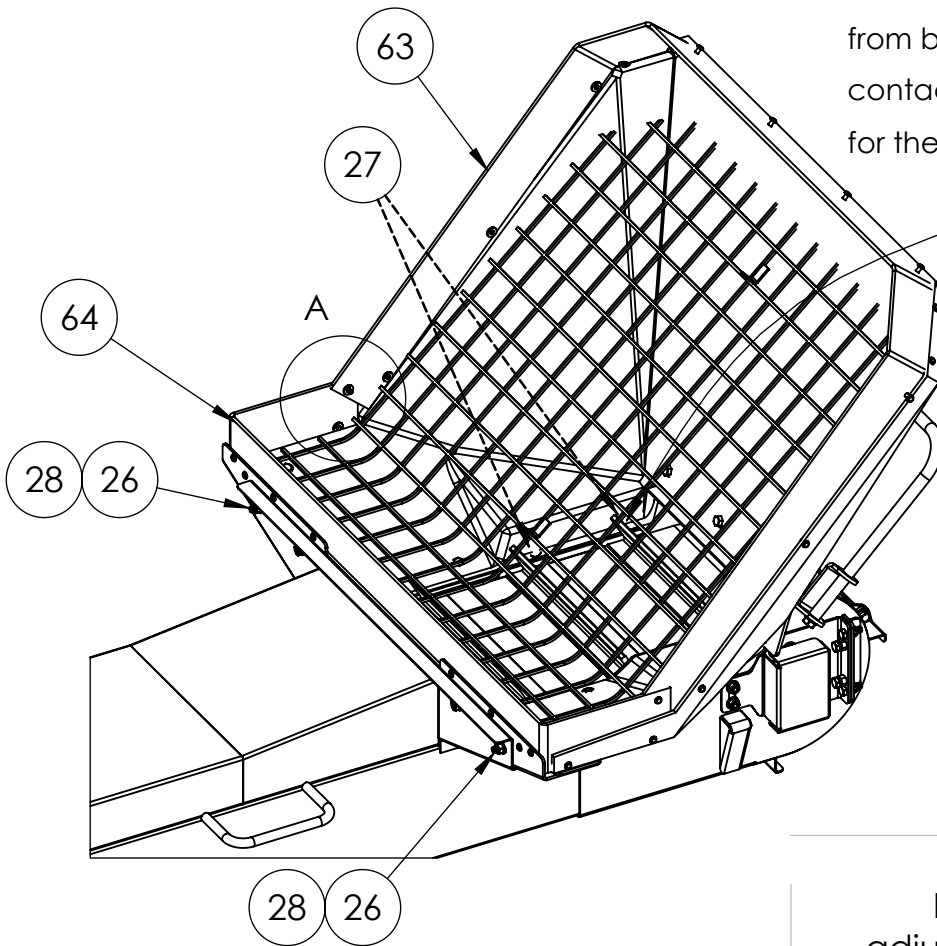

To attach the hopper extensions (63) & (64), use rivets (72) with washers (73) on the inside. Drill holes for the rivets below the hopper rim.

Installing & Adjusting the adjustable bottom roller bracket

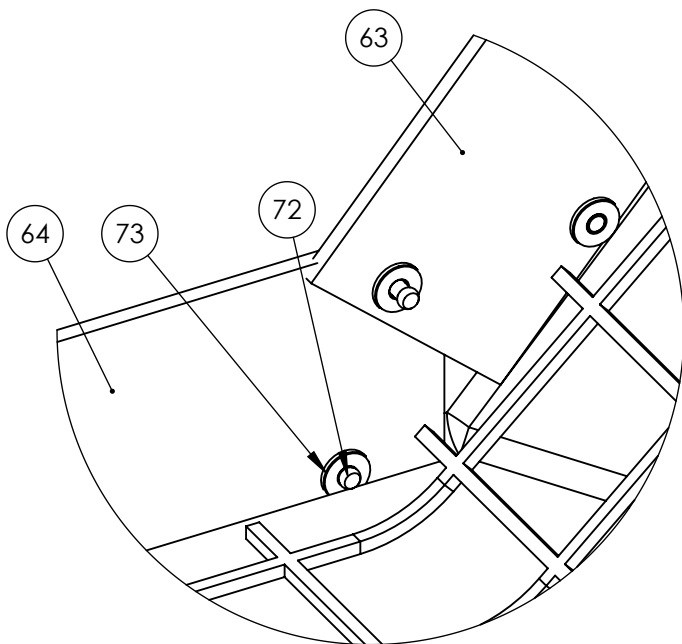

DETAIL A

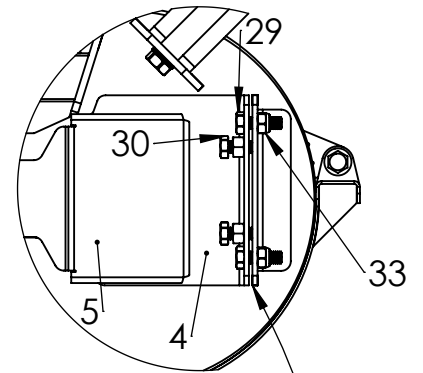

Leave a space of approximately 4mm. Adjust this to correct belt tracking. Increase the gap to track belt to the left.

IMPORTANT: To avoid thread galling when using stainless steel bolts and nuts DO NOT use power tools to pull peices together.

